

F2-02DAS-1, ISOLATED 2-CHANNEL ANALOG CURRENT OUTPUT



In This Chapter...

Module Specifications	12-2
Connecting the Field Wiring	12-5
Module Operation	12-7
Writing the Control Program.....	12-11

Module Specifications

The F2-02DAS-1 Analog Output module provides several hardware features:

- Analog outputs are isolated from channel to channel and channel to PLC logic.
- The module has a removable terminal block so the module can be easily removed or changed without disconnecting the wiring.
- All channels can be updated in one scan if either a D2-240, a D2-250-1, D2-260 or a D2-262 CPU is used in the PLC.
- Outputs are sourced through external loop supply.
- Loop power supply requirements: 18–32 VDC

Firmware Requirements:

- To use this module, D2-230 CPUs must have firmware version 1.7 or later.
- To use the pointer method for writing values, D2-240 CPUs require firmware version 2.9 or later.
- D2-250 CPUs require firmware version 1.30 or later.

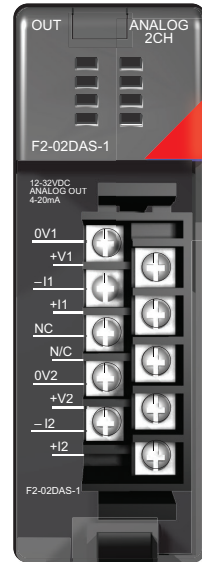

F2-02DAS-1

The following tables provide the specifications for the F2-02DAS -1, Isolated Analog Output Module.

Output Specifications	
Number of Channels	2, isolated (2 commons)
Output Range	4–20 mA
Resolution	16 bit (1 in 65536)
Output Type	Current sourcing
Isolation Voltage	±750V continuous, channel to channel, channel to logic
Loop Supply	18–32 VDC
Max Load Impedance	525Ω
Linearity Error (end to end)	±10 counts (±0.015% of full scale) maximum
Conversion Settling Time	3ms to 0.1% of full scale
Gain Calibration Error	±32 counts (±0.05%)
Offset Calibration Error	±13 counts (±0.02%)
Output Drift	50ppm / °C
Maximum Inaccuracy	±0.07% @ 25°C (77°F) ±0.18% 0–60 °C (32–140 °F)

General Specifications	
PLC Update Rate	1 channel per scan maximum (multiplexing) 2 channels per scan maximum (pointer – D2-240/D2-250-1/D2-260 and D2-262 only)
Digital Outputs / Output Points Required	16 binary data bits, 2 channel ID bits; 32 point (Y) output module
Power Budget Requirement	100mA @ 5VDC (supplied by the base)
External Power Supply	18–32 VDC, 50mA per channel, Class 2
Operating Temperature	0–60 °C (32–140 °F)
Storage Temperature	-20°C to 70°C (-4°F to 158°F)
Relative Humidity	5–95% (non-condensing)
Environmental Air	No corrosive gases permitted
Vibration	MIL STD 810C 514.2
Shock	MIL STD 810C 516.2
Noise Immunity	NEMA ICS3-304

Analog Output Configuration Requirements

The F2-02DAS-1 analog output module requires 32 discrete output points. The module can be installed in any slot of a DL205 system, but the available power budget and discrete I/O points are the limiting factors. Check the DL205 PLC User Manual for the particular model of CPU and I/O base being used for information regarding power budget and number of local, local expansion or remote I/O points.

Special Placement Requirements (D2-230 and Remote I/O Bases)

It is important to examine the configuration if a D2-230 CPU is being used in a multiplexing program. As can be seen in the section on **Writing the Control Program**, V-memory locations are used to hold the analog data that will be written to the output. If the module is placed in a slot so that the output points do not start on a V-memory boundary, the program instructions aren't able to access the data. This also applies when placing this module in a remote base using a D2-RSSS in the CPU slot.

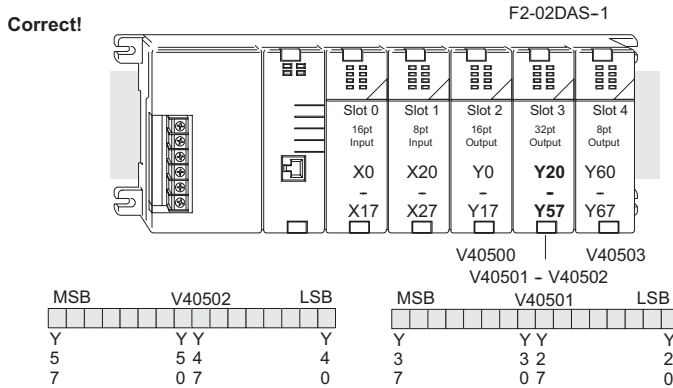

Data can be written correctly because the output points start on a V-memory boundary address as seen in the table above.

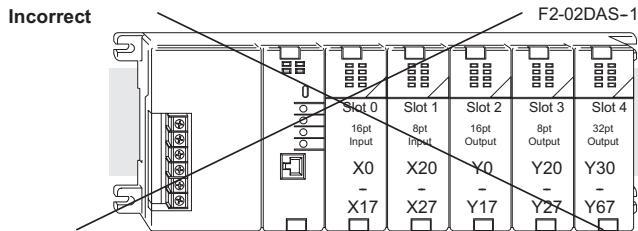

Data is split over three locations, so instructions cannot access data from a D2-230 (or when module is placed in a remote I/O base).



To use the V-memory references required for a D2-230 CPU, the first output address assigned to the module must be one of the following Y locations. The table also shows the V-memory addresses that correspond to these Y locations.

Y	Y0	Y20	Y40	Y60	Y100	Y120	Y140	Y160
V	V40500	V40501	V40502	V40503	V40504	V40505	V40506	V40507

Connecting the Field Wiring

Wiring Guidelines

Your company may have guidelines for wiring and cable installation. If so, check the guidelines before beginning the installation. Here are some general things to consider:

- Use the shortest wiring route whenever possible.
- Use shielded wiring and ground the shield at the transmitter source. Do not ground the shield at both the module and the source.
- Do not run the signal wiring next to large motors, high current switches, or transformers. This may cause noise problems.
- Route the wiring through an approved cable housing to minimize the risk of accidental damage. Check local and national codes to choose the correct method for your application.

Loop Power Supply Requirements

The F2-02DAS-1 module requires at least one field-side power supply. Separate power sources should be used to maintain the channel to channel isolation. The F2-02DAS-1 module requires 18–32 VDC (at 50mA per channel) from the external power supply.

The DL205 AC bases have a built-in 24VDC power supply that provide up to 300mA of current. This can be used instead of a separate supply. Check the power budget to be safe.

It is desirable in some situations to power the transmitters separately in a location remote from the PLC. This will work as long as the transmitter supply meets the current requirements, and the transmitter's negative (-) side and the module supply's negative (-) side are connected together.



WARNING: If the internal 24VDC base power is used, be sure to calculate the power budget. Exceeding the power budget can cause unpredictable system operation that can lead to a risk of personal injury or equipment damage.

Wiring Diagram

The F2-02DAS-1 module has a removable connector which helps to simplify wiring. Squeeze the top and bottom retaining clips and gently pull the connector from the module. Use the following diagram to connect the field wiring.

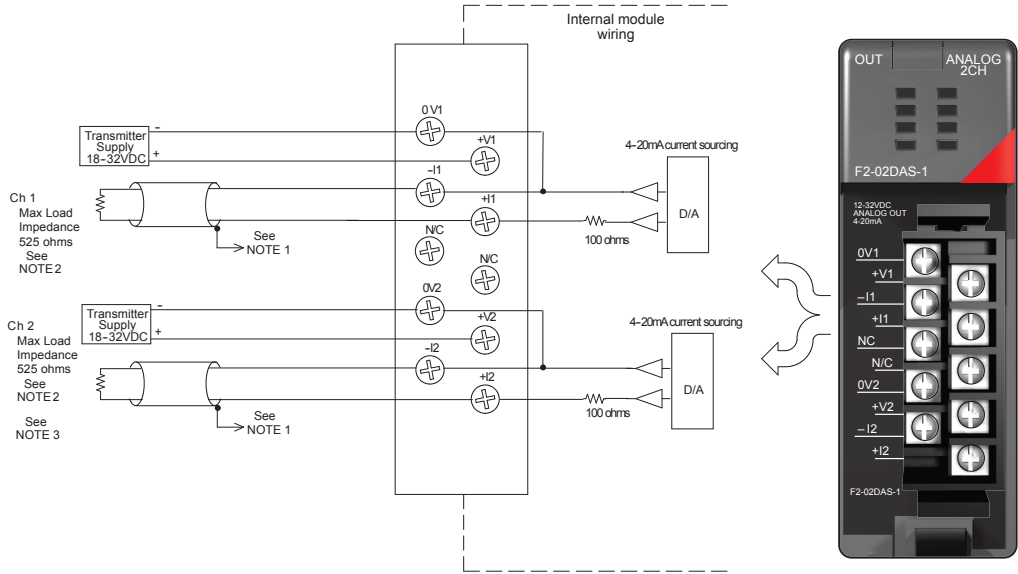

NOTE 1: Shields should be connected to the 0V terminal of the module or 0V of the power supply.

NOTE 2: Loads must be within the compliance voltage.

NOTE 3: For non-isolated outputs, connect (0V1 & 0V2) together and connect (+V1 & +V2) together

Module Operation

Before beginning to write the control program, it is important to take a few minutes to understand how the module processes the analog signals.

Channel Update Sequence (Multiplexing) for a D2-230 CPU

If a multiplexing program is being used, only one channel of data can be sent to the output module on each scan. The module refreshes both field devices on each scan, but new data can only be obtained from the CPU at the rate of one channel per scan. Since there are two channels, it can take two scans to update both channels. However, if only one channel is being used, that channel will be updated on every scan. The multiplexing method can also be used for the D2-240, D2-250-1, D2-260 and D2-262 CPUs.

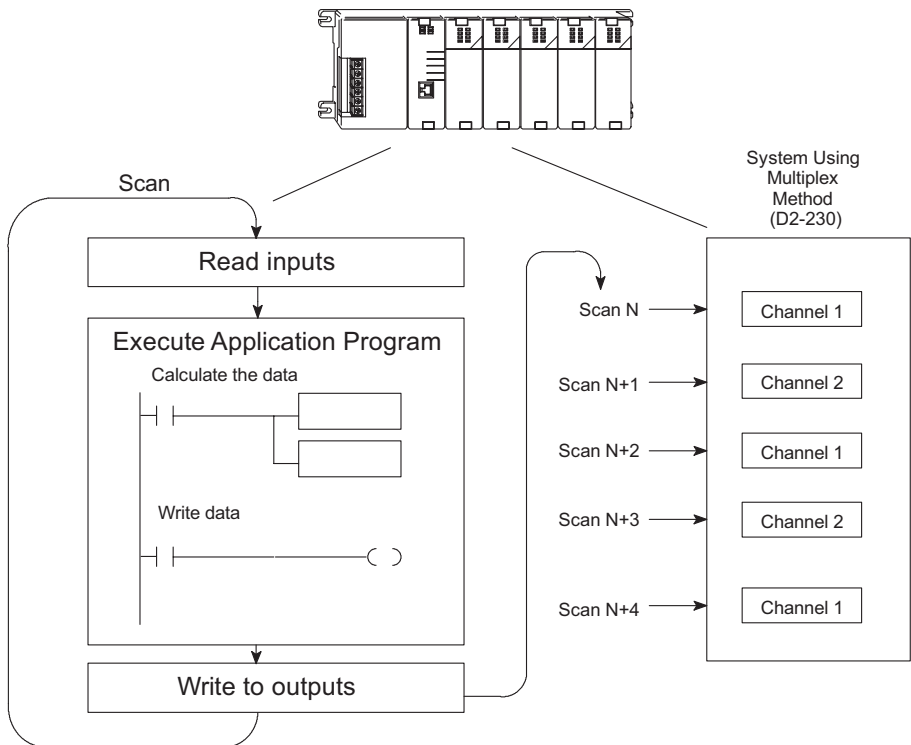

Channel Update Sequence (Pointer Method) for D2-240, D2-250-1, D2-260 and D2-262 CPUs

If either a D2-240, D2-250-1, D2-260 or D2-262 CPU is used with the pointer method, all channels can be updated on every scan. This is because the three CPUs support special V-memory locations that are used to manage the data transfer. This is discussed in more detail in the section on **Writing the Control Program** later in this chapter.

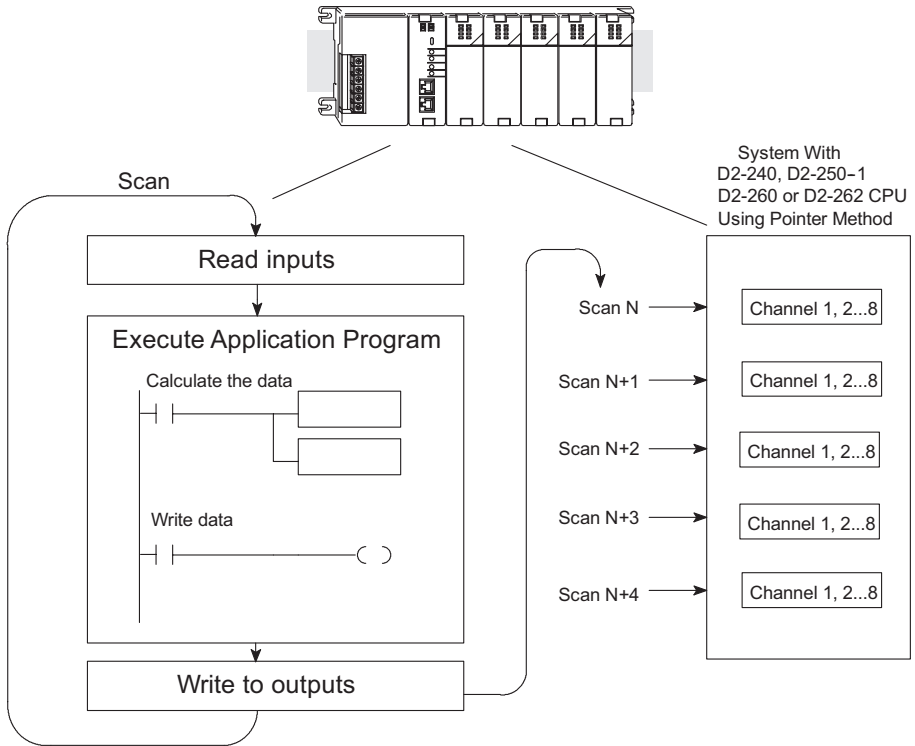

Understanding the Output Assignments

Remember that the F2-02DAS-1 module appears to the CPU as a 32-point discrete output module. These points provide the data value and an indication of which channel to update. Note, if either a D2-240, D2-250-1, D2-260 or D2-262 CPU is being used, these bits may never have to be used, but it may be an aid to help understand the data format.

Since all output points are automatically mapped into V-memory, the location of the data word that will be assigned to the module can simply be determined.

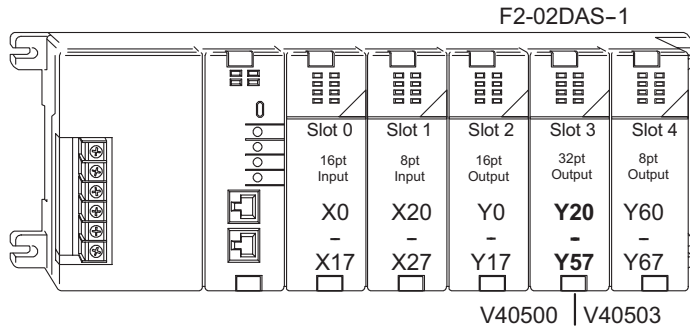

The individual bits in this data word location, represents specific information about the analog signal.

Channel Select Outputs

Two of the outputs select the active channel. Remember, the V-memory bits are mapped directly to discrete outputs. Turning a bit OFF selects a channel. By controlling these outputs, the channel to be updated is selected.

Y41	Y40	Channel
On	Off	1
Off	On	2
Off	Off	1 & 2 (same data to both channels)
On	On	None (both channels hold current values)

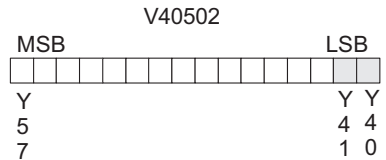

□ = channel select outputs

Analog Data Bits

The first sixteen bits represent the analog current in binary format.

Bit	Value	Bit	Value
0	1	8	
1	2	9	
2	4	10	1024
3	8	11	2048
4	16	12	4096
5	32	13	8192
6	64	14	16384
7	128	15	32768

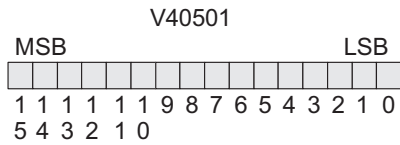

□ = data bits

Module Resolution

Since the module has 16-bit resolution, the analog signal is converted into 65536 counts ranging from 0-65535 (2^{16}). For example, send a 0 to get a 4mA signal, and 65535 to get a 20mA signal. This is equivalent to a binary value of 0000 0000 0000 0000 to 1111 1111 1111 1111, or 0000 to FFFF hexadecimal. The diagram below shows how this relates to the signal range.

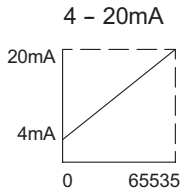

$$\text{Resolution} = \frac{H - L}{65535}$$

H = High limit of the signal range

L = Low limit of the signal range

$$16\text{mA} / 65535 = 0.2241 \mu\text{A per count}$$

Each count can also be expressed in terms of the signal level by using the equation shown.

Writing the Control Program

Calculating the Digital Value

The control program must calculate the digital value that is sent to the analog output. Several methods can be used to do this, but the best method is to convert the values to engineering units. This is accomplished by using the formula shown.

Adjustments may need to be made to the formula depending on the scale of the engineering units.

$$A = U \frac{65535}{H - L}$$

A = Analog Value (0 – 65535)

U = Engineering Units

H = High limit of the engineering unit range

L = Low limit of the engineering unit range

Consider the following example which controls pressure from 0.0–99.9 PSI. Using the formula will calculate the digital value to be sent to the analog output. The example shows the conversion required to yield 49.4 PSI. The multiplier of 10 is because the decimal portion of 49.4 cannot be loaded in the program, so it is shifted right one decimal place to make a usable value of 494.

$$A = 10U \frac{65535}{10(H - L)} \quad A = 494 \frac{65535}{1000 - 0} \quad A = 32374$$

Refer to the example on the next page to write the conversion program.

Engineering Units Conversion

This example program shows how to write the program to perform the engineering unit conversion to output data formats 0–65535 when using a D2-250-1 CPU. This example assumes that a BCD value has been stored in V2300 for channel 1.

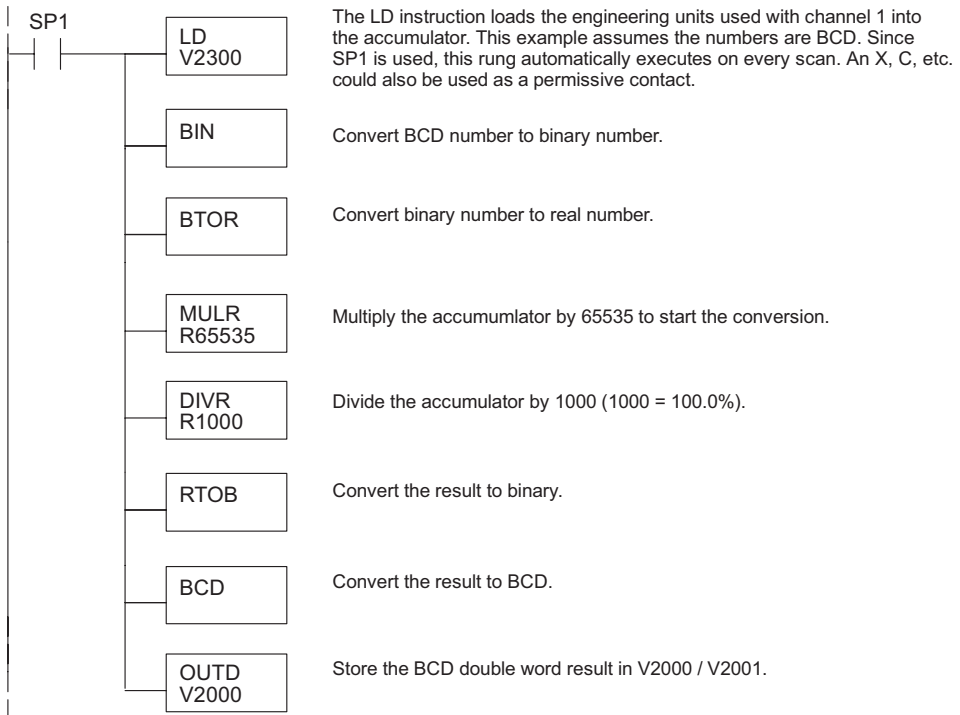

Writing Values: Pointer Method and Multiplexing

Two methods are used to read data values:

- Pointer method
- Multiplexing

The multiplexing method must be used with a D2-230 CPU. The multiplexing method must also be used with remote I/O modules (the pointer method will not work). Either method can be used with the D2-240, D2-250-1, D2-260 and D2-262 CPUs, but for ease of programming it is highly recommended to use the pointer method.

Pointer Method for D2-240, D2-250-1, D2-260 and D2-262 CPUs

The D2-240, D2-250-1, D2-260 and D2-262 CPUs have special V-memory locations assigned to each base slot that will greatly simplify the programming requirements.

These V-memory locations allow you to:

- Specify the data format
- Specify the number of channels to scan
- Specify the location of the data that will be written to the module



NOTE: D2-240 CPUs with firmware release version 3.0 or later and. D2-250 CPUs with firmware release version 1.33 or later support this method.

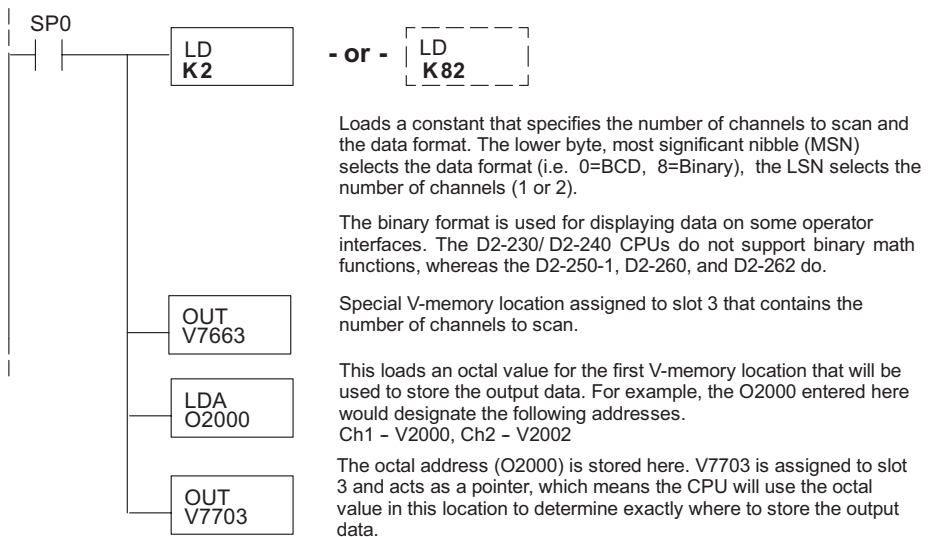

The following example program shows how to setup these locations. Place this rung anywhere in the ladder program, or in the initial stage if stage programming instructions are being used. In this example V2000 and V2002 are used to store the calculated values, the analog module is installed in slot 3. Be sure to use the V-memory locations for the module placement. The pointer method automatically converts values to binary.

The following tables show the special V-memory locations used by the D2-240, D2-250-1, D2-260 and D2-262 for the CPU base and local expansion base I/O slots. Slot 0 (zero) is the module next to the CPU or D2-CM module. Slot 1 is the module two places from the CPU or D2-CM, and so on. Remember, the CPU only examines the pointer values at these locations after a mode transition. Also, if the D2-230 (multiplexing) method is used, verify that these addresses in the CPU are 0 (zero).

The table below applies to the D2-240, D2-250-1, D2-260 and D2-262 CPU base.

CPU Base: Analog Output Module Slot-Dependent V-memory Locations								
Slot	0	1	2	3	4	5	6	7
No. of Channels	V7660	V7661	V7662	V7663	V7664	V7665	V7666	V7667
Storage Pointer	V7700	V7701	V7702	V7703	V7704	V7705	V7706	V7707

The table below applies to the D2-250-1, D2-260 or a D2-262 CPU base 1.

Expansion Base D2-CM #1: Analog Output Module Slot-Dependent V-memory Locations								
Slot	0	1	2	3	4	5	6	7
No. of Channels	V36000	V36001	V36002	V36003	V36004	V36005	V36006	V36007
Storage Pointer	V36020	V36021	V36022	V36023	V36024	V36025	V36026	V36027

The table below applies to the D2-250-1, D2-260 or a D2-262 CPU base 2.

Expansion Base D2-CM #2: Analog Output Module Slot-Dependent V-memory Locations								
Slot	0	1	2	3	4	5	6	7
No. of Channels	V36100	V36101	V36102	V36103	V36104	V36105	V36106	V36107
Storage Pointer	V36120	V36121	V36122	V36123	V36124	V36125	V36126	V36127

The table below applies to the D2-260 and D2-262 CPU base 3.

Expansion Base D2-CM #3: Analog Output Module Slot-Dependent V-memory Locations								
Slot	0	1	2	3	4	5	6	7
No. of Channels	V36200	V36201	V36202	V36203	V36204	V36205	V36206	V36207
Storage Pointer	V36220	V36221	V36222	V36223	V36224	V36225	V36226	V36227

The table below applies to the D2-260 and D2-262 CPU base 4.

Expansion Base D2-CM #4: Analog Output Module Slot-Dependent V-memory Locations								
Slot	0	1	2	3	4	5	6	7
No. of Channels	V36300	V36301	V36302	V36303	V36304	V36305	V36306	V36307
Storage Pointer	V36320	V36321	V36322	V36323	V36324	V36325	V36326	V36327

Write Data Example (Multiplexing)

Since all channels are multiplexed into a single data word, the control program can be setup to determine which channel to write the data to. Since the module appears as Y output points to the CPU, it is simple to use the channel selection outputs to determine which channel to update.

Note, this example is for a module installed in slot 3, as shown in the previous examples. The addresses used would be different if the module was used in a different slot. These rungs can be placed anywhere in the program or if stage programming is being used, place them in a stage that is always active.

This example is a two-channel multiplexer that updates each channel on alternate scans. Relay SP7 is a special relay that is on for one scan, then off for one scan. This multiplexing example can be used with all of the DL205 CPUs.



NOTE: Binary data must be sent to the output module. If the data is already in binary format, do not use the BIN instruction shown in this example.

Load data into the accumulator.

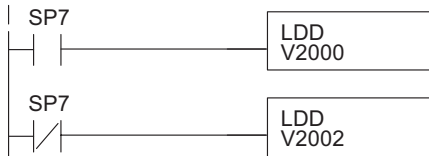

Loads the data for channel 1 into the accumulator.
Note: Use LD if using binary, and use LDD if using BCD.

Loads the data for channel 2 into the accumulator.
Note: Use LD if using binary, and use LDD if using BCD.

Send data to V-memory assigned to the module.

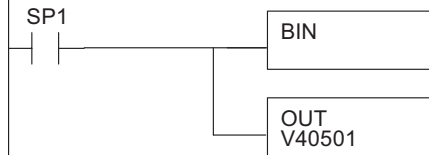

Convert the data to binary (you must omit this step if you have converted the data elsewhere). SP1 is always on.

The OUT instruction sends the data to the module. Our example starts with V40501, but the actual value depends on the location of the module in your application.

Select the channel to update.

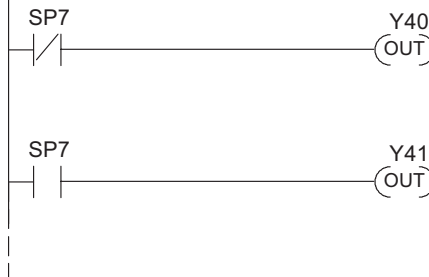

Selects channel 2 for update when Y41 is OFF (Y40-ON deselects channel 1). Note, Y40 and Y41 are used as in the previous examples. If the module was installed in a different I/O arrangement the addresses would be different.

Selects channel 1 for update when Y41 is OFF (Y41-ON deselects channel 2). Note, Y40 and Y41 are used as in the previous examples. If the module was installed in a different I/O arrangement the addresses would be different.

Write Data to One Channel

If only one channel is being used, or if the updates are to be controlled separately, the following program can be used.

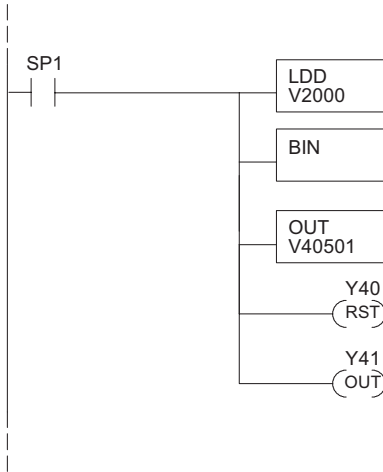

The LD instruction loads the data into the accumulator. Since SP1 is used, this rung automatically executes on every scan. X, C, etc. can also be used as permissive contacts.

Note: Use LD if using binary, and use LDD if using BCD.

The BIN instruction converts the accumulator data to binary (you must omit this step if you have already converted the data elsewhere).

The OUT instruction sends the data to the module. Our example starts with V40501, but the actual value depends on the location of the module in your application.

Y40-OFF selects channel 1 for updating.

Y41-ON deselected channel 2 (do not update).

Write the same Data to Both Channels

If both channel select outputs are off, then both channels will be updated with the same data.

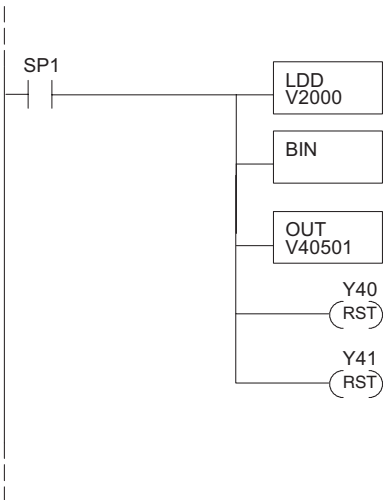

The LD instruction loads the data into the accumulator. Since SP1 is used, this rung automatically executes on every scan. The X, C, etc. can also be used as permissive contacts.

Note: Use LD if using binary, and use LDD if using BCD.

The BIN instruction converts the accumulator data to binary (you must omit this step if you have already converted the data elsewhere).

The OUT instruction sends the data to the module. Our example starts with V40501, but the actual value depends on the location of the module in your application.

Y40-OFF selects channel 1 for updating.

Y41-OFF selects channel 2 for updating.

Analog and Digital Value Conversions

It is sometimes useful to do quick conversions between the signal levels and the digital values. This can be helpful during startup and/or troubleshooting. The following table shows some formulas to help with the conversions.

Range	If the digital value is known	If the analog signal level is known.
4-20 mA	$A = \frac{16D}{65535} + 4$	$D = \frac{65535}{16} (A - 4)$

For example, if a 10mA signal level is needed, use the formula to the right to determine the digital value “D” to be stored in the V-memory location which is designated to store the data.

$$D = \frac{65535}{16} (A - 4)$$

$$D = \frac{65535}{16} (10\text{mA} - 4)$$

$$D = (4095.94) (6)$$

$$D = 24575 (5FFFh)$$